

Electric Service Requirements Guideline (Residential)

Silicon Valley Power
1500 Warburton
Santa Clara, CA 95050
(408) 261-5292

Revised 3/1/06

Included in this guideline are the following:

- 1) How to Contact Us – guideline for whom to contact regarding various questions
- 2) Information At a Glance – general information regarding connection of electric service
- 3) Process for New or Upgraded Electric Service
- 4) Flowchart of Process for New or Upgraded Electric Service
- 5) Service Acknowledgement Forms (required submission)
- 6) Residential Disconnect/Reconnect Procedures
- 7) Load Survey Information Sheet (required submission)
- 8) Sample Plot Plan (required submission)
- 9) Sample of Municipal Fees
- 10) Ground Clearances for Residential Service Drops
- 11) Residential Electric Underground Service Requirements
- 12) Residential Electric Overhead Service Requirements (OH 550)
- 13) Residential Meter Socket Configurations
- 14) Meter Installation Guidelines
- 15) Tree Clearances
- 16) City Approved Residential Tree List
- 17) Portable or permanent Electric Generator Report Form
- 18) Swimming Pool Clearances

How to Contact Us

City Departments:

Planning Department	(408) 615-2450
Permit Center	(408) 615-2420
<ul style="list-style-type: none">• Permit questions• Temporary Power Applications	
Building Inspection Division	(408) 615-2440
<ul style="list-style-type: none">• Periodic and final inspections	
Automated Inspection Request & Permit Status	(408) 615-2400
Municipal Services Division	(408) 615-2300
<ul style="list-style-type: none">• Sign up for billing of utility services• Ring out of electric meters	
Engineering Department	(408) 615-3000
<ul style="list-style-type: none">• Encroachment into electrical easements	
City Arborist	(408) 615-3081
<ul style="list-style-type: none">• Questions regarding acceptable trees in proximity to electric right-of-ways or power lines	

Silicon Valley Power:

Electric Estimating and Engineering	(408) 261-5343
<ul style="list-style-type: none">• Relocation of electric facilities• Swimming pool/spa electrical clearance info• New electric services• Upgrades to existing electric services	
Electric Meter Shop	(408) 615-5626
Service Coordinator/Inspector	(408) 640-6302
<ul style="list-style-type: none">• Joint trench• Inspection of contractor-installed facilities up to point of service	
Key Customer Representatives	(408) 615-5651

Other Useful Numbers:

Underground Service Alert (USA)	1-800-227-2600
<ul style="list-style-type: none">• Call 2 days in advance before digging	

This is a guide to Silicon Valley Power's requirements for the installation of electric service. It is meant to provide a general guideline to assist you in installing or upgrading electric service in the City of Santa Clara. In addition to Silicon Valley Power's requirements, the City of Santa Clara Building Department's requirements must be met. If you have questions that are not answered by this guideline, please contact the appropriate department listed on the contact page at the front of this guideline.

INFORMATION AT A GLANCE

Connection of Electric Service:

- Only one service point will be granted to one building; Silicon Valley Power will determine the customer's service point and voltage.
- Normally, overhead service drop voltage will be 120/240 volts and underground service voltage will be 120/208 volts.
- If more than one electric meter is required the meters must be grouped at one location.
- Multiple-meter installations of three or more meters will require three-phase service to the main board, and requires a ring out through the Municipal Services Division.
- The maximum meter main size for a residential service is 200 Amperes single phase.
 - Exception: For 120/240v service with 80% rated main, maximum meter main size is 400 Amperes single phase
- Only authorized Silicon Valley Power employees are permitted to make connections between Silicon Valley Power's system and customer's wiring.
- Service cannot be connected unless approved by the City's Building Department Electric Inspector.
- Silicon Valley Power will install and maintain **overhead** service drops (conductors from SVP's pole line to the weather head). Customer is responsible for installation and maintenance of underground service conductors.
- For additional information not included in this section or in the attached standards, please see the "How to Contact Us" section at the front of the guideline for the appropriate contact phone number.

Encroachment Requests:

A homeowner may want to encroach into the City's Right-of-Way (Public Utility Easements, Electrical Easements, etc.) with eaves of dwellings, storage sheds, concrete swimming pools, spa equipment pads, or other permanent structures. Generally, these requests are granted through encroachment permits, which are subject to approval of the City. However, the homeowner is required to sign a covenant with the City and pay a one-time fee. Requests for encroachment into Right-of-Ways should be obtained from the City's Engineering Department.

Trees:

In the vicinity of overhead power lines

Trees planted under power lines should be limited to species that will grow 25 feet or less (see recommended list).

In the vicinity of electric underground lines

If trees are to be planted within 5 feet of an underground power line, root barriers should be used. (For additional information please contact the City's arborist in the Street Department.)

Process for New or Upgraded Electric Service

*Note: For relocation or upgrades to existing service, skip steps 2-5.
Steps 2-5 do not apply to jobs that can be approved at City staff level.*

New Service:

1. Submit an application, preliminary site plan, and fees to the Planning Department.
2. The Planning Department will forward plans to all city departments involved, including the Electric Department, Silicon Valley Power (SVP).
3. SVP will review the plans for electric service strategy and make recommendations through the Project Clearance Committee.
4. Once accepted as complete by the Project Clearance Committee, the project will go to the Planning Commission and/or City Council for approval.
5. Once approved, the Architectural Review Committee will review the project.
6. When approved by the Architectural Review Committee, if applicable, the customer develops the detailed plans and submits them to the Permit Center, along with the permit application, Electric Load Survey, Service Acknowledgement Form, and Plan Check Fee.
7. The Permit Center Technician distributes copies of plans to SVP, and other City departments, for review.
8. SVP reviews plans and provides electric planning review and a “developer’s work” drawing, if required.
9. Once plans are approved by SVP, they are forwarded to the Plans Examiner who signs off when all city departments have approved the plans.
10. The customer then picks up the permit and pays all permit fees and other applicable fees.
11. The customer begins construction work and contacts the Building Inspection’s Electrical Inspector for periodic inspections.
12. The SVP Service Coordinator/inspector tracks progress of the project and communicates to SVP staff concerned with the project.
13. SVP construction work is scheduled and plans are forwarded to the Meter Shop and Electric Construction & Maintenance Divisions.

14. The SVP Service Coordinator/Inspector inspects developer's work done for the City.
15. SVP Electric Construction & Maintenance Division pulls the electric service, but does not energize at this time.
16. The Sr. Meter Technician reviews plans for meter installation as soon as proposed switchboard information is known. When approved, the drawings are stamped and a copy is sent back to the customer.
17. The Sr. Meter Technician monitors the project and installs the meter when the panel is ready.
18. The customer contacts the Municipal Services Division to sign up for service.
19. The Customer contacts Building Inspection's Electrical Inspector for a final inspection.
20. When the Building Inspection's Electrical Inspector approves the project, an inspection release is sent to the Municipal Services Division.
21. The Municipal Services Division matches the Inspection Release with the customer's request for service and opens a utility account. A copy is sent to the Meter Shop.
22. When the Meter Shop receives the billing information and the inspection release, the service is energized*.

*Note: Any required Easement documents or Riser Agreements must be signed and approved before service can be energized.

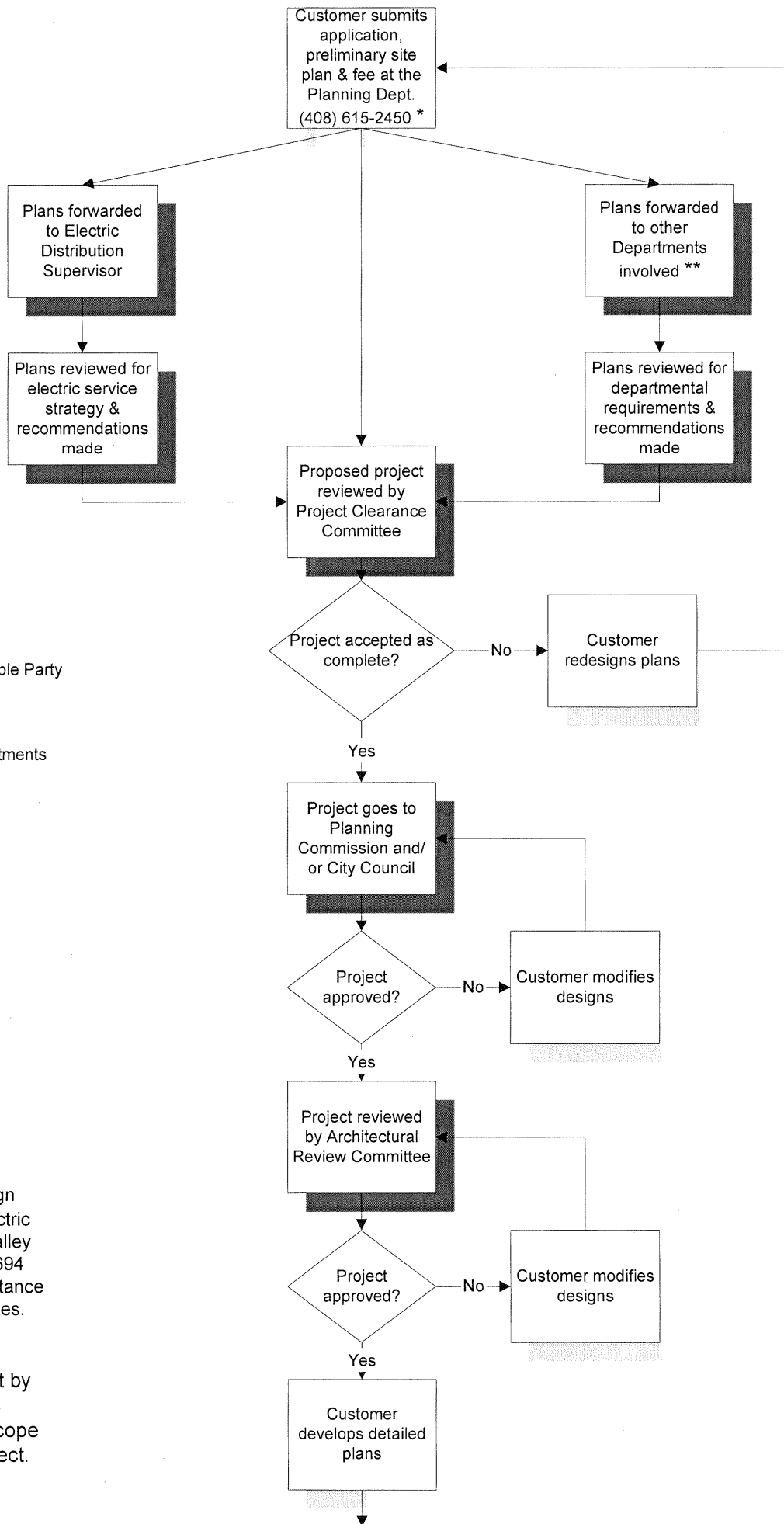

Legend for Responsible Party

- Customer
- City Departments

*During the initial design phase, contact the Electric Department (Silicon Valley Power) at (408) 615-5694 regarding design assistance or any applicable rebates.

**Note: Involvement by other departments is determined by the scope of the individual project.

upgrades to service typically start at this point in the process

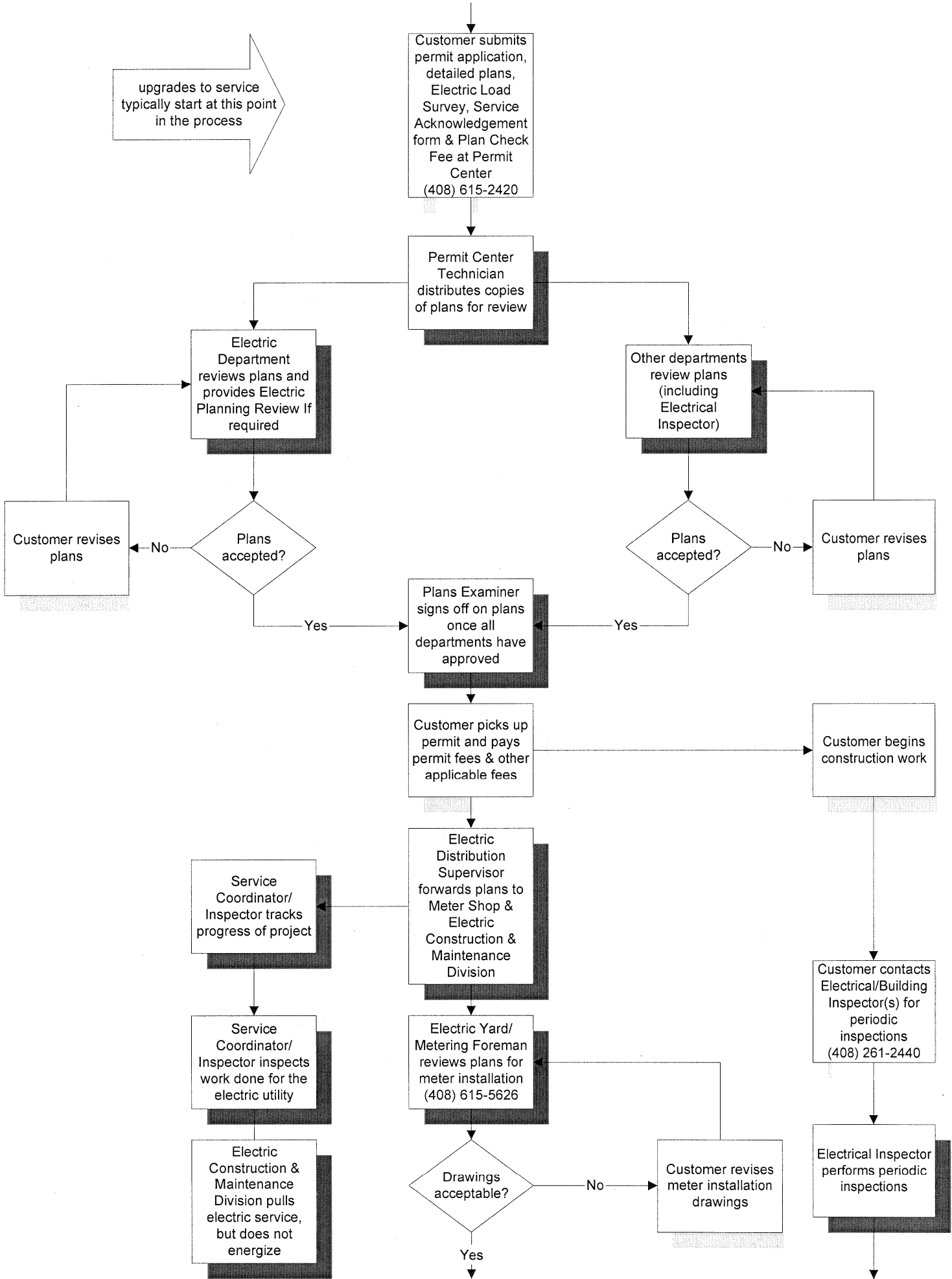

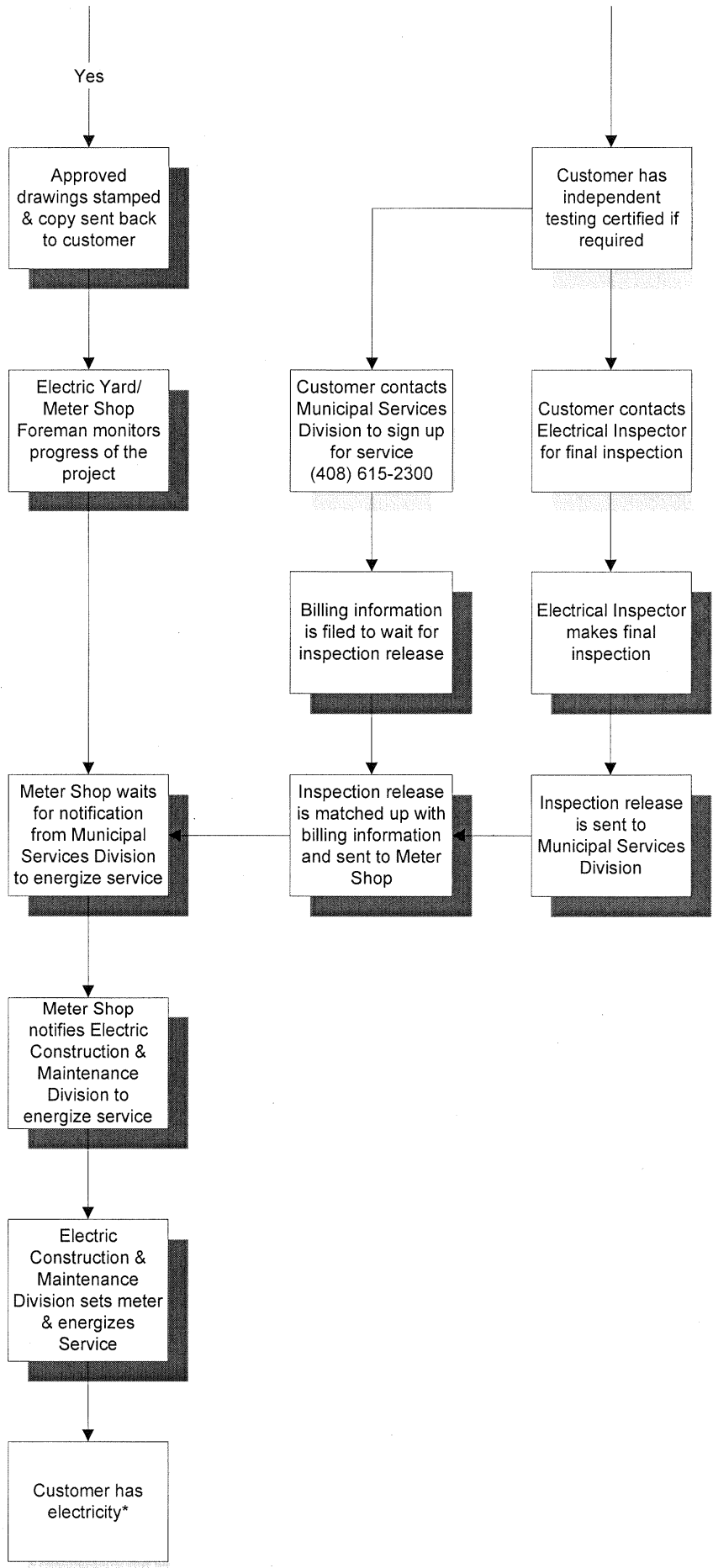

*Note: Easement documents and/or Riser Agreements must be signed and approved before service can be energized

THE CITY OF SANTA CLARA SILICON VALLEY POWER

COMMERCIAL/INDUSTRIAL/RESIDENTIAL ELECTRICAL SERVICE ACKNOWLEDGEMENT

Welcome to Silicon Valley Power (SVP), the City of Santa Clara's Municipal Electric Utility. When installing a new electrical service, modifying or upgrading an existing electrical service, adding electrical load in an existing facility, or renting/leasing an existing commercial/industrial building, please contact SVP before starting work.

1. Please read and sign this sheet, fill out the attached SVP Load Survey and Information sheet Form ED 205-1 for Commercial and Industrial or Form ED 205-2 for Residential, and submit this sheet and the load survey sheet to SVP. No work on your project can be scheduled until this completed form is received.
2. For overhead service, the attached SVP Engineering Standard OH 550, sheets 1 through 4 latest revisions are applicable. Please retain these sheets for your reference and use.
3. For underground service, the requirements are covered in SVP's Engineering Standard UG 1000 latest revisions.
4. The SVP Design Section will determine the location of the overhead service drop, the underground service lateral connection point, and the specific metering requirements.
5. Customers requesting service at primary voltage (12kv) shall submit a protection coordination study to the SVP Planning Section for coordination requirement.
6. SVP will be pleased to advise you in other requirements you may have concerning your service installation. Please call at (408) 261-5343.

Please note that failure to contact SVP, or to comply with their requirements, will result in electric service not being provided.

I acknowledge that I have read the above information and that I will comply with it.

Signature of Permittee

Building Inspection Copy

**THE CITY OF SANTA CLARA
SILICON VALLEY POWER**

**COMMERCIAL/INDUSTRIAL/RESIDENTIAL ELECTRICAL
SERVICE ACKNOWLEDGEMENT**

Welcome to Silicon Valley Power (SVP), the City of Santa Clara's Municipal Electric Utility. When installing a new electrical service, modifying or upgrading an existing electrical service, adding electrical load in an existing facility, or renting/leasing an existing commercial/industrial building, please contact SVP before starting work.

7. Please read and sign this sheet, fill out the attached SVP Load Survey and Information sheet Form ED 205-1 for Commercial and Industrial or Form ED 205-2 for Residential, and submit this sheet and the load survey sheet to SVP. No work on your project can be scheduled until this completed form is received.
8. For overhead service, the attached SVP Engineering Standard OH 550, sheets 1 through 4 latest revisions are applicable. Please retain these sheets for your reference and use.
9. For underground service, the requirements are covered in SVP's Engineering Standard UG 1000 latest revisions.
10. The SVP Design Section will determine the location of the overhead service drop, the underground service lateral connection point, and the specific metering requirements.
11. Customers requesting service at primary voltage (12kv) shall submit a protection coordination study to the SVP Planning Section for coordination requirement.
12. SVP will be pleased to advise you in other requirements you may have concerning your service installation. Please call at (408) 261-5343.

Please note that failure to contact SVP, or to comply with their requirements, will result in electric service not being provided.

I acknowledge that I have read the above information and that I will comply with it.

Signature of Permittee

Customer Copy

CITY OF SANTA CLARA
Office of the
Building Official
1500 Warburton Ave.
Santa Clara, CA 95050

Inspection División: (408) 615-2440
Permit Center: (408) 615-2420
Automated Inspection System: (408) 615-2400
FAX: (408) 241-3823

REQUIREMENTS FOR RESIDENTIAL ELECTRICAL DISCONNECT/RECONNECT SERVICE

The following steps are required for a residential electrical disconnect:

1. The applicant is hereby informed to call the Inspection Division one working day before you require the City to disconnect electrical service to your house. Calls to disconnect electrical service will be taken the day before by 3:30 p.m. ONLY. Under NO circumstances are you to disconnect and remove meter. Check with Electrical Inspector if you have any questions about the procedure to follow. **(NOTE: No disconnects will be provided on Mondays)**.
2. Upon disconnect request, caller (permit holder) to be advised that the disconnect shall be performed between 8:00 a.m. and 9:00 a.m. of the day requested, and reconnect shall normally occur, following Inspector's approval on permit card, that same afternoon between 2:00 and 4:00 p.m.
3. The owner or contractor **MUST** be present at the job site locations, if questions arise concerning disconnection procedures.
4. Any further questions regarding disconnect/reconnect, call the electrical inspector between the hours of 8:00 a.m.-5:00 p.m., Monday thru Friday.

THE CITY OF SANTA CLARA SILICON VALLEY POWER

LOAD SURVEY AND INFORMATION SHEET FOR RESIDENTAL DEVELOPMENT

TO ALL DEVELOPERS, BUILDERS, CONTRACTORS, AND TENANTS:

If homeowner is upgrading his main size but not adding any additional electric load this form is not required. To help us complete our review of your plans and to assist us in establishing the service you require when you need it, please complete this form and return it to the attention of the City of Santa Clara Electric Department Design Section, along with any applicable drawings and electrical diagrams.

PROJECT NAME _____ OWNER _____
Address _____

Architect/Civil Engineer _____ Phone _____
Address _____

Electrical Contractor _____ Phone _____
Address _____

Date service required _____

ELECTRIC LOAD INFORMATION

New Building or Added Load to existing Building (Check One)

	Single Family	Multi-family (Individual Unit)
Electric Heating	<input type="checkbox"/>	<input type="checkbox"/>
Electric Water Heating	<input type="checkbox"/>	<input type="checkbox"/>
Air Conditioning	<input type="checkbox"/>	<input type="checkbox"/>
Electric Cooking	<input type="checkbox"/>	<input type="checkbox"/>
Over 1500 ft ² of floor space	<input type="checkbox"/>	<input type="checkbox"/>
Main size	_____ amps	_____ amps

If new or replaced underground electric service, Developer is required to install per Building Inspection requirements. Please indicate number of conductors per phase__ and wire size____ number of conductors per neutral__ and size____

If Multi-family (Entire Building)

Main panel size _____ amps
House meter size _____ amps
Number of units per building _____ units
Number of Elevators__ and size _____ hp

If you have any questions, please feel free to call us. By working on your needs now, we can avoid possible delays in providing electric service to your building. If you have any questions please call us at (408) 261-5343. Thank you for your cooperation.

STREET

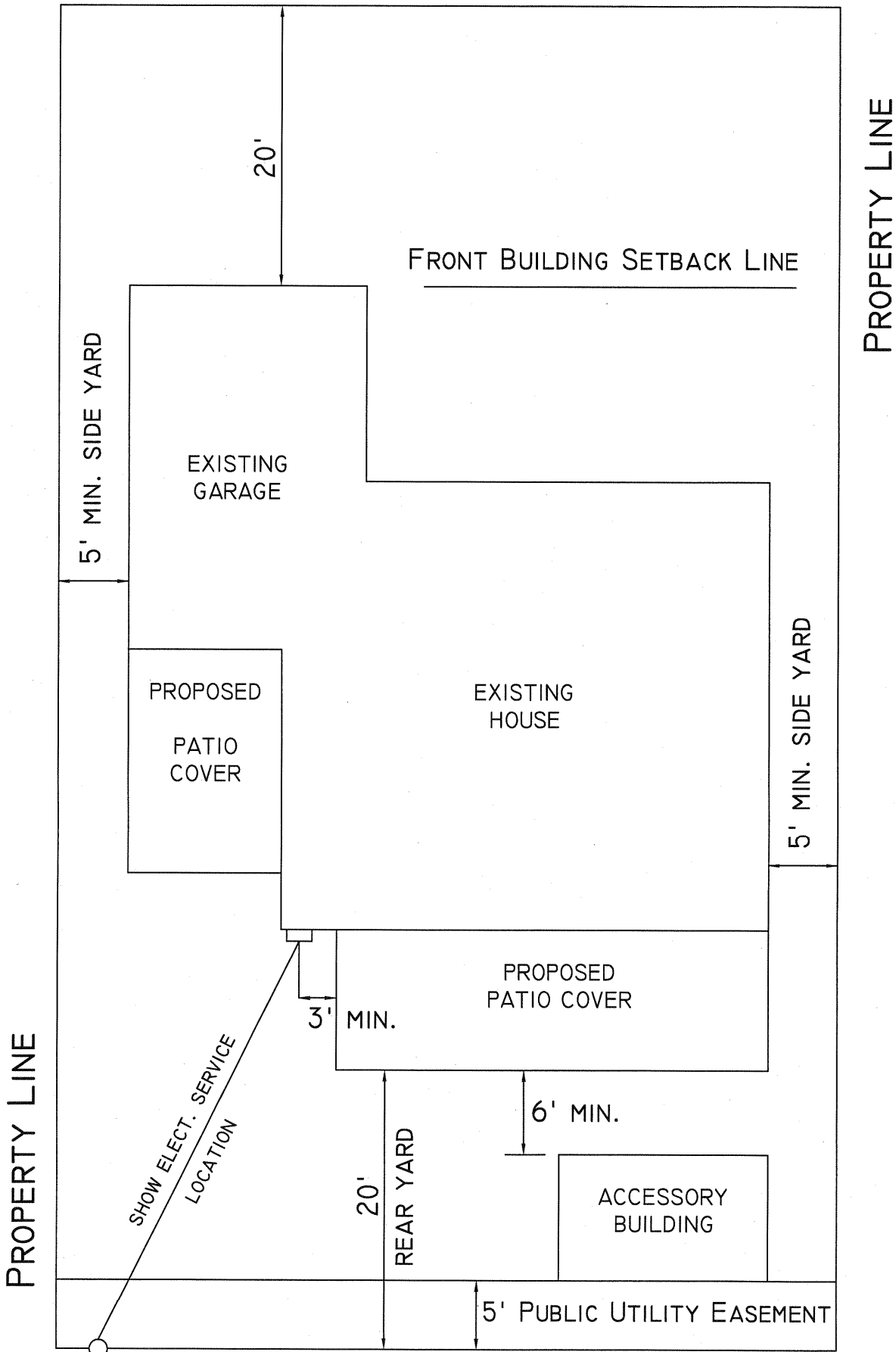

SAMPLE
PLOT PLAN

Municipal Fees

The following is a sample of some of the fees charged for Electric Utility services. Actual cost will be determined by the rates in effect at the time of filing or requesting services.

Development Fees

Overhead Lines - New Single Family/Residential	\$758.98 per lot
Overhead Lines - New Multiple Units	\$467.25 per unit
Overhead Lines - Street Lighting	\$4.68 per front foot
Underground - New Single Family/Residential	\$1,118.78 per lot
Underground - New Multiple Units	\$998.08 per unit
Underground - New Street Lighting	\$11.55 per front foot
Underground - New Street Lighting (over 10 acres)	\$1,763.75 per front foot
Underground - Existing Single Family	\$2,198.23 per lot
Underground - Existing Multi-Units	\$1,175.50 per unit
Underground - Existing Street Lighting	\$17.16 per front foot

Service Fees

Temporary Pole Connection	\$235.10
Underground Street Light Relocation	Actual Cost
Service Wire Relocation from Mid-Span	\$270.65
Service Wire Relocation from Pole	\$177.10
Service Reconnection at the Pole	\$119.70
Service Reconnection at the Weather Head	\$39.13

These fees were effective July 1st, 2007 and are subject to change based on City Council Approval. For most current fees, please check with the Permit Center.

Elevation at point of attachment shall be such that all required vertical clearances can be maintained with allowance for normal conductor sag.

24" min. clearance radially if more than 15 ft. from point of building attachment of either service. If less than 15 ft., clearance may be 12" min.

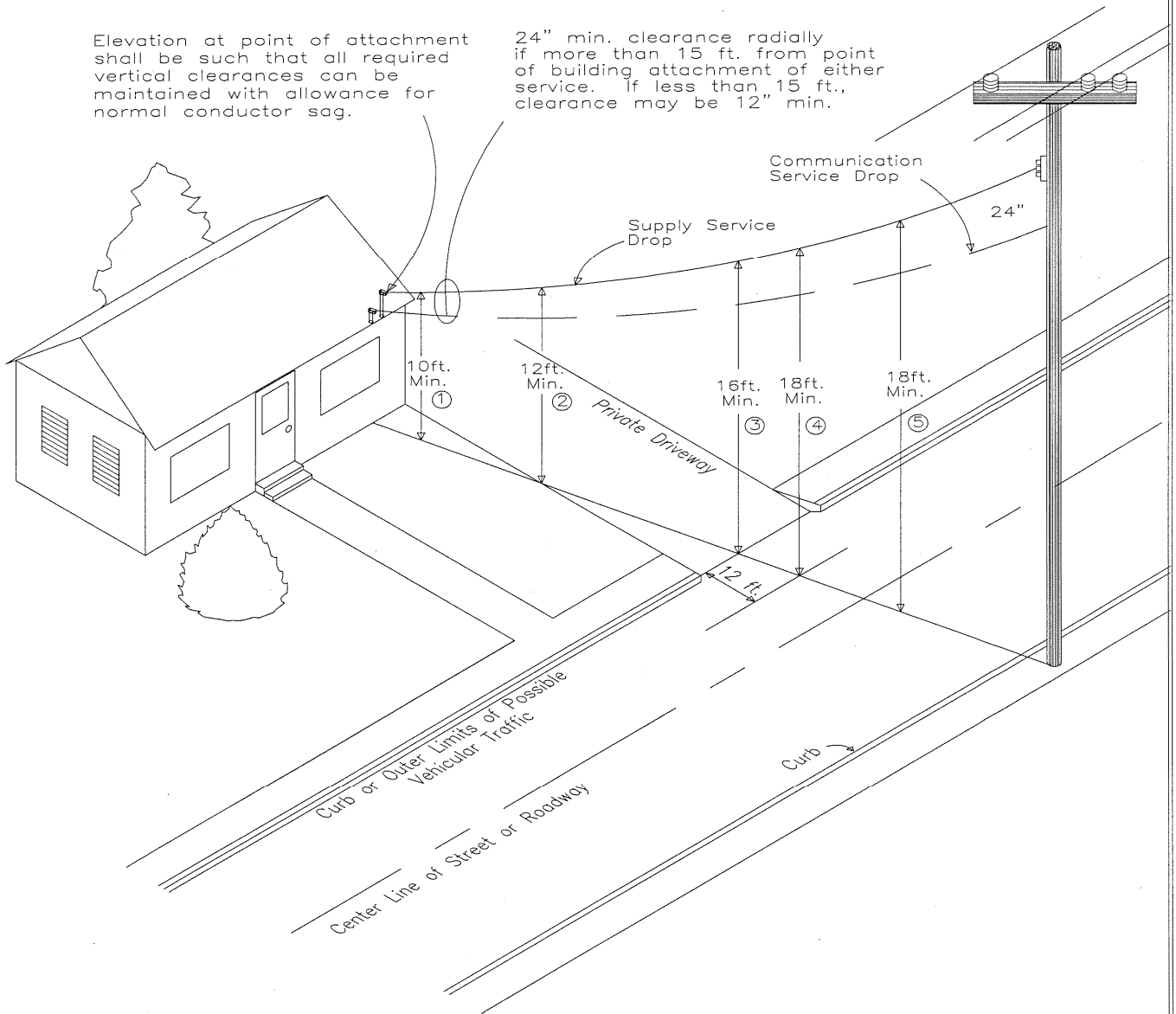

- ① Over residential property, accessible to pedestrians only – 10ft.
- ② Over private driveways & areas accessible to vehicles – 12ft.
- ③ Over public streets, at curb line, from street level – 16ft.
- ④ & ⑤ Over the center portion of street or roadway (12ft. from curb) – 18ft.

Note: Accessory Building Clearance

DESIGNED BY:	EE	GROUND CLEARANCES FOR SERVICE DROPS	DRAWN BY: EE	
APPROVED BY:			SCALE: NONE	DATE: 8/03
			MAP #:	SHT OF
		SILICON VALLEY POWER	DRAWING NUMBER	REV
		CITY OF SANTA CLARA		0

CITY OF SANTA CLARA
Building Inspection Division

1500 Warburton Ave.
Santa Clara, CA 95050
(408) 615-2440

RESIDENTIAL ELECTRIC UNDERGROUND SERVICE REQUIREMENTS

1. Permittee is responsible for installation of on-site underground conduit and wire conformity with the currently adopted edition of the National Electrical Code.
2. Rock-free backfill (sand or native soil) properly compacted, shall be used to provide a smooth bedding and cover for conduit. In lieu of rock-free backfill, rigid galvanized steel conduit shall be used (IN SERVICE TRENCH ONLY).
3. Rigid galvanized steel or PVC schedule 40 UL approved non-metallic conduit may be used with no more than four (4) 90 degree long sweep bends. Minimum size conduit 2 inches (2").
4. A joint trench is acceptable, in addition to electrical conduit, for telephone and cable television lines. Sewer, sanitary or storm drain piping are not permitted. Gas piping must have prior approval.
5. Service conduits must be placed a minimum of 24 inches (24") below grade to afford proper cover. Other facilities conduit must be separated from service conduit a minimum of 12 inches (12").
6. Non-metallic conduit may be placed less than the 24 inches (24") minimum cover limit unless protected by concrete or changed to rigid galvanized conduit. In addition to 24 inches (24") cover, a warning ribbon at least 12 inches (12") in above underground installation must be installed.
7. Inspection and approval of completed conduit placement is required before backfilling.
8. Risers:
 - a. Service Riser conduit shall be 2 inch (2") making all lengths consistent with this notation method of rigid galvanized steel installed per City of Santa Clara Electric Department Engineering Standard UG 1000 sheet 37 latest revision.
 - b. Contact City of Santa Clara Electric Department Design Section at (408) 261-5343 to obtain the following:
 1. Riser quadrant location.
 2. Pole riser agreement.
 3. Length of service conductors required above pole riser conduit is 30ft. unless specified otherwise in the pole riser agreement. Conductors shall be coiled at top of riser conduit. City will connect these conductors to overhead electric system.
 4. Minimum and maximum size service conduit is 2 inches (2").
 5. Grounding of rigid galv. steel is required
9. For further information call Building Inspection Division at (408) 615-2440.

CITY OF SANTA CLARA
Building Inspection Division

1500 Warburton Ave.
Santa Clara, CA 95050
(408) 615-2440

RESIDENTIAL ELECTRIC OVERHEAD SERVICE REQUIREMENTS

1. Service mast(s) shall be a minimum of one and one fourth inches (1-1/4") rigid steel conduit continuous.
2. Service mast(s) must be a minimum of 30 inches (30") above roof line continuous.
3. Service mast(s) must be braced if length exceeds 36 inches (36"). Service mast(s) height without bracing shall limited to 30 inches above the roof in locations where the service drop must be installed through trees, or where trees or the tree branches may strike or cause unplanned loading on the service drop.
4. Service mast(s) must be braced with a two-hole pipe strap nearest to 30 inches (30") under eaves or side fascia.
5. Service mast(s) projecting above roofs or eaves shall be continuous without couplings from point of attachment of utility service drop to below the roof or eaves.
6. Service mast(s) penetrations through wood roofs or wood sheathing must have flashing.
7. Service drop shall be attached to a periscope mast(s) on the roof not more than 18 inches (18") back of that wall, if practical.
8. You must provide a minimum of conductor out of your weather head for proper drip loop. Neutral conductor must be identified with white tape.
9. Service shall not be attached directly to metal roofs. Service drop cable shall clear all roofs by a minimum vertical distance of eight feet (8') . And three feet (3') if roof is greater than 4 and 12 slope in roof.
10. Service conductors must have a clearance of not less than 3 feet (3') from windows designed to open, doors, porches, balconies, ladders, stairs, fire escapes, or similar locations.
11. For a service disconnect of your service conductors, an inspection and request for disconnect must be arranged 24 hours in advance with the Building Inspection Division at 615-2440. Disconnects are made by the City of Santa Clara Electric Department between 8:00 a.m. to 9:00 p.m. and reconnects between 2:00 p.m. and 3:00 p.m. that same day. No disconnects are provided on Mondays. OWNER or CONTRACTOR must be present to have service disconnected.
12. For further information, please call Building Inspection Division at 408-615-2440.

GENERAL REQUIREMENTS

1. Prior to starting any new service installation, or making any changes to existing service(s), Customer shall fill in "Load Survey and Information Sheet" (ED-205) and return to the City of Santa Clara, Electric Department, Design Section, Telephone (408) 261-5343.
2. City Electric Department Design Section will determine the service point, service type (overhead or underground) and available service voltage.
3. For overhead service, the following requirements, as shown below and on sheets 2, 3, and 4, shall apply. (Note: For underground service, requirements are covered in Engineering Standard UG 1000.)
4. Typical arrangement of service mast(s), main(s), and meter(s) for all new service installations or rework (modifications) of existing installations, shall be as shown.

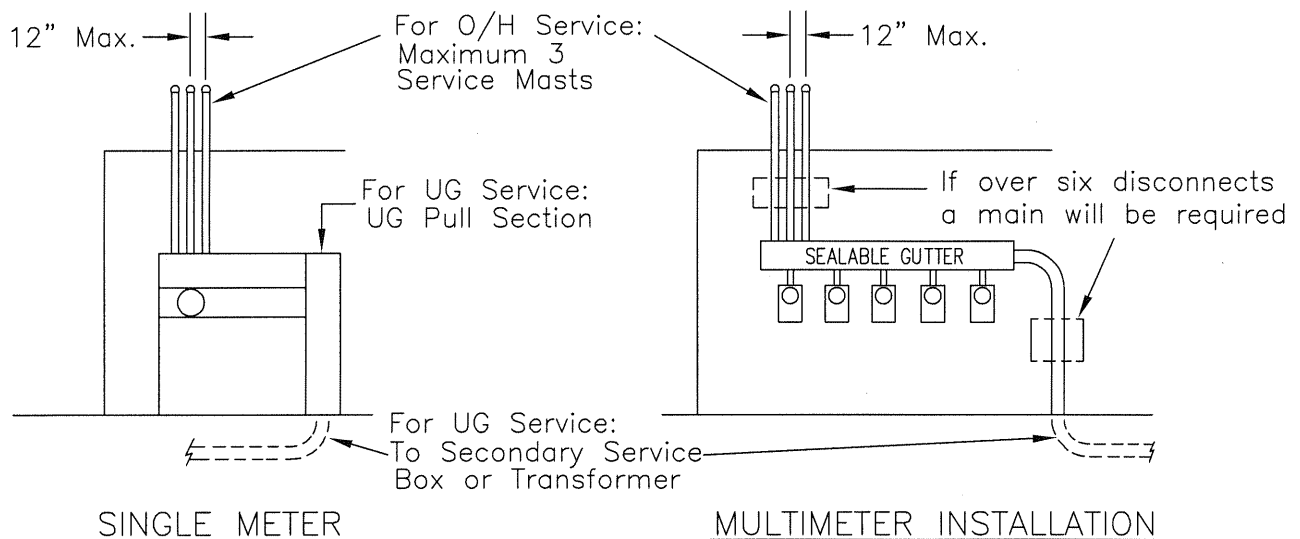

5. All meters shall be grouped at one location approved by the City Electric Department, Design Section. The City shall have direct and unrestricted access to the meters at all times. The meters may be installed outside (preferable), or inside in a specially designated Utility Room with direct outside access.
6. Meter installation heights shall comply with the following:
 Meters installed Outdoors: Min. 48"; Max. 75"
 Meters installed in a Cabinet or Indoors in a meter room: Min. 36"; Max. 75"
 Meter height shall be measured from the ground or standing surface to the meter center line.
7. On all commercial installations (0-200A) the customer shall furnish an approved manual Test-By Pass.
8. For metering requirements and approvals, contact Electric Department Meter Shop, Telephone (408) 615-5626.

5	8/18/95	Modified revision no.	P.G.	6	1/11/06	Updated information	
3	3/18/92	Added meter heights, dwg on CAD	MJK	4	7/27/93	Added Note 7	
REV	DATE		APPRVD	REV	DATE		APPRVD

DESIGNED BY: P. GRECO	ELECTRIC SERVICE REQUIREMENTS OVERHEAD		DRAWN BY: WPS
APPROVED BY: P.H.E.			SCALE: NTS
DATE: 3/86	CITY OF SANTA CLARA		SHT 1 OF 4
			DRAWING NUMBER: OH 550
SILICON VALLEY POWER			

OVERHEAD SERVICE REQUIREMENTS

1. Service Voltages Available:

For Single-Family Residential:

120/240V 3W 1Ø

120/208V 3W 1Ø

For Multiple-Family Residential:

120/240V 3W 1Ø (in most cases)

120/208V 3W 1Ø

For Industrial/Commercial:

120/208V 4W 3Ø

120/240V 4W 3Ø

480V 3W 3Ø

(Note: 480/277V is available only with an underground service).

2. Maximum Main Size:

120/208V 3W 1Ø - 200A

120/208V 4W 3Ø - 1200A

120/240V 3W 1Ø - 400A

120/240V 4W 3Ø - 1200A

480V 3W 3Ø - 600A

NOTE:

For larger main sizes an Underground Service will be required.

3. Maximum number of weatherheads per service drop:

Three

4. Maximum weatherhead conductor size:

750 MCM CU or AL

5. Minimum length of weatherhead tails:

4'-0" — Commercial & Industrial 2'-0" — Residential

6. City will not connect more than 4 conductors per phase and neutral.

7. Obtain service racks from City of Santa Clara Service Center at 1705 Martin Ave. in Santa Clara. Size of rack(s) and location to be determined by City Electric Department, Design Section. Obtain Estimate Number from the Design Section prior to obtaining racks.

8. Point of service attachment, whether on Building, Service Masts, or build-up structure, shall be capable of safely supporting the strain imposed by the service drop.

9. Service Mast(s) shall be a continuous piece of rigid electrical conduit. Conduits shall be sized according to NEC with a minimum of 1-1/4". Couplings will not be permitted.

5	8/18/95	Modified revision no.	P.G.	6	1/11/06	Updated information	
3	3/18/92	Added meter heights, dwg on CAD	MJK	4	7/27/93	Added Note 7	
REV	DATE		APPRVD	REV	DATE		APPRVD

DESIGNED BY: P. GRECO	ELECTRIC SERVICE REQUIREMENTS OVERHEAD	DRAWN BY: WPS
APPROVED BY: P.H.E.	DATE: 3/86	SCALE: NTS DATE: 7/93
	SILICON VALLEY POWER	SHT 2 OF 4
	CITY OF SANTA CLARA	DRAWING NUMBER: OH 550 REV: 6

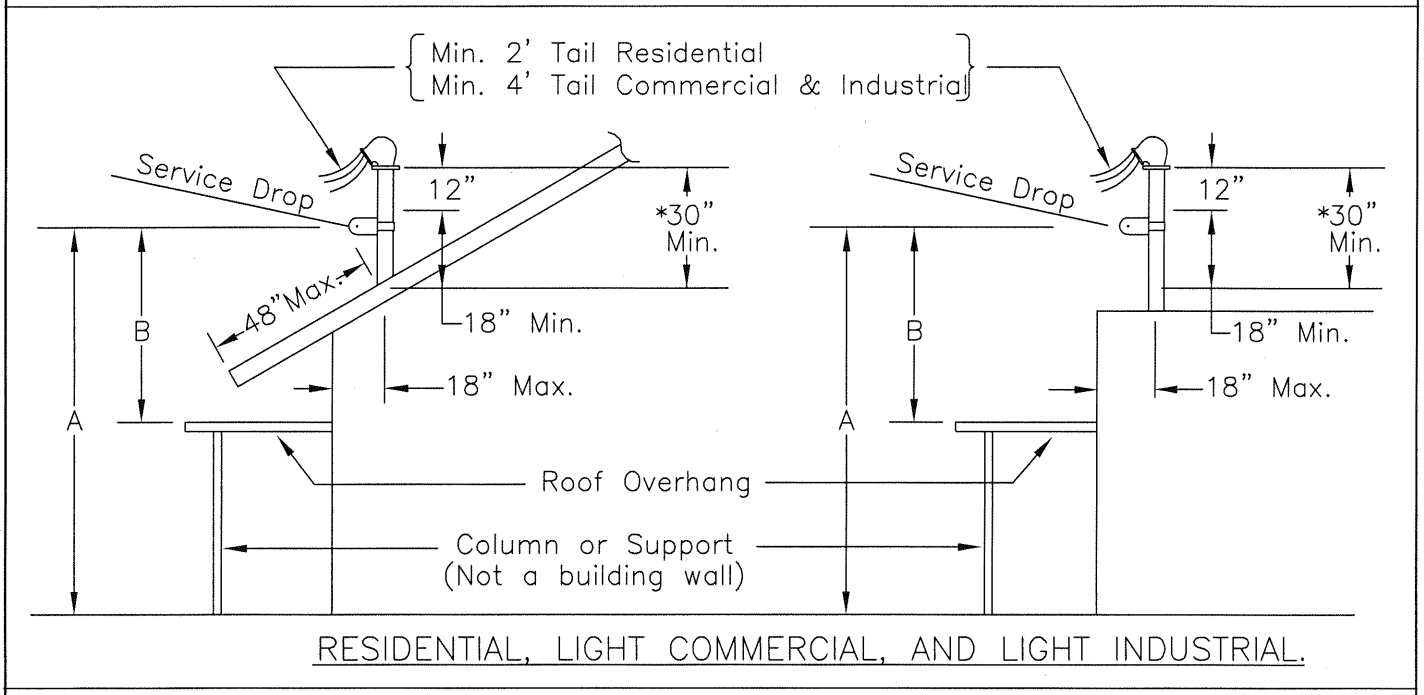
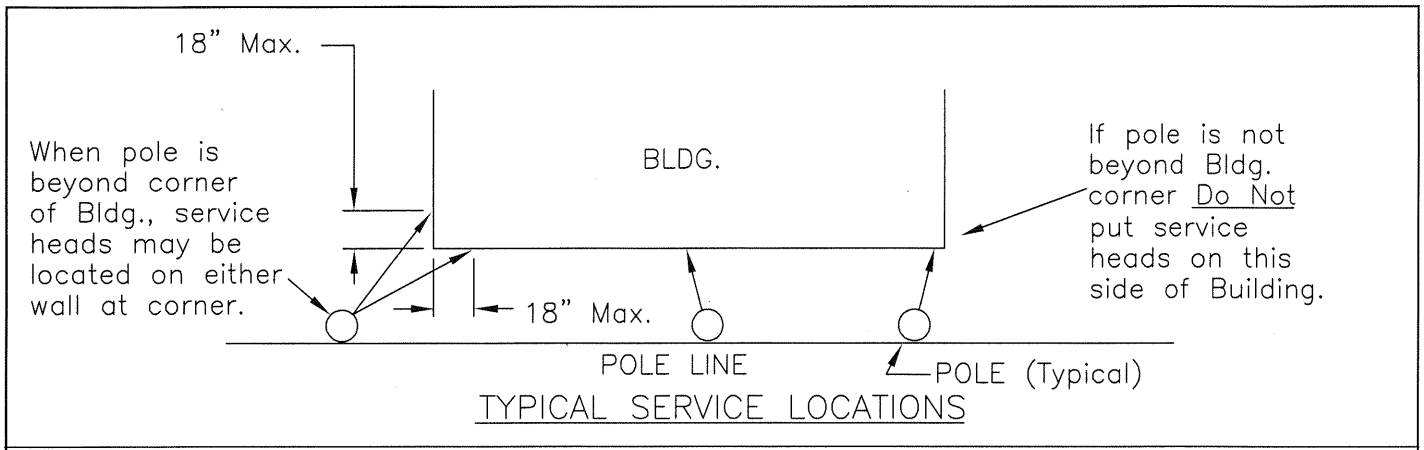

DIMENSIONS FOR SHEETS 3 & 4

RESIDENTIAL :

- "A" Dimension = 12'-0" Min. over driveway
10'-0" Min. over pedestrian-only area
- "B" Dimension = 8'-0" Min. over walkable roof or metallic roof
2'-0" Min. over non-walkable & non-metallic roof

COMMERCIAL AND INDUSTRIAL :

- "A" Dimension = 18'-0" Min. over street, private driveway and/or area where vehicles can be driven
12'-0" Min. over pedestrian-only area
- "B" Dimension = 8'-0" Min. over walkable roof
2'-0" Min. over non-walkable & non-metallic roof

* If this dim. exceeds 30" bracing shall be required.

5	8/18/95	Modified revision no.	P.G.	6	1/11/06	Updated information	
3	3/18/92	Added meter heights, dwg on CAD	MJK	4	7/27/93	Added Note 7	
REV	DATE		APPRVD	REV	DATE		APPRVD
DESIGNED BY: P. GRECO		ELECTRIC SERVICE REQUIREMENTS OVERHEAD				DRAWN BY: WPS	
APPROVED BY:	DATE					SCALE: NTS	DATE: 7/93
P.H.E.		3/86			SHT 3 OF 4		
CITY OF SANTA CLARA				DRAWING NUMBER		REV	
				OH 550		6	

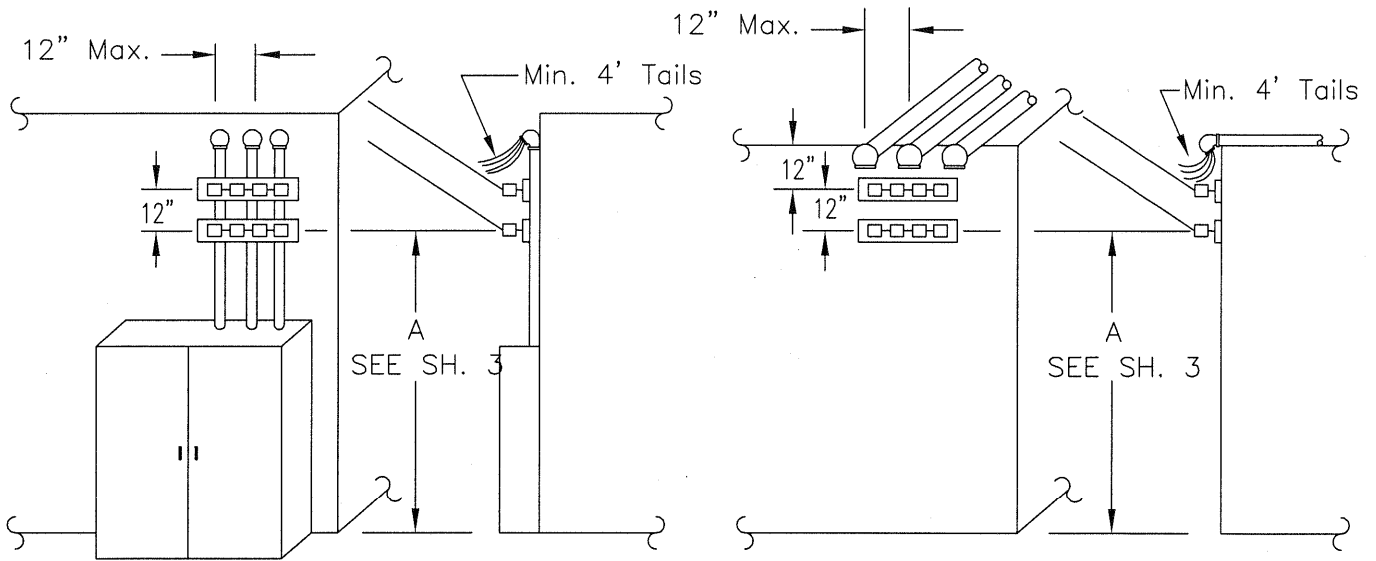

COMMERCIAL AND INDUSTRIAL
Service mast(s) below or at top of building

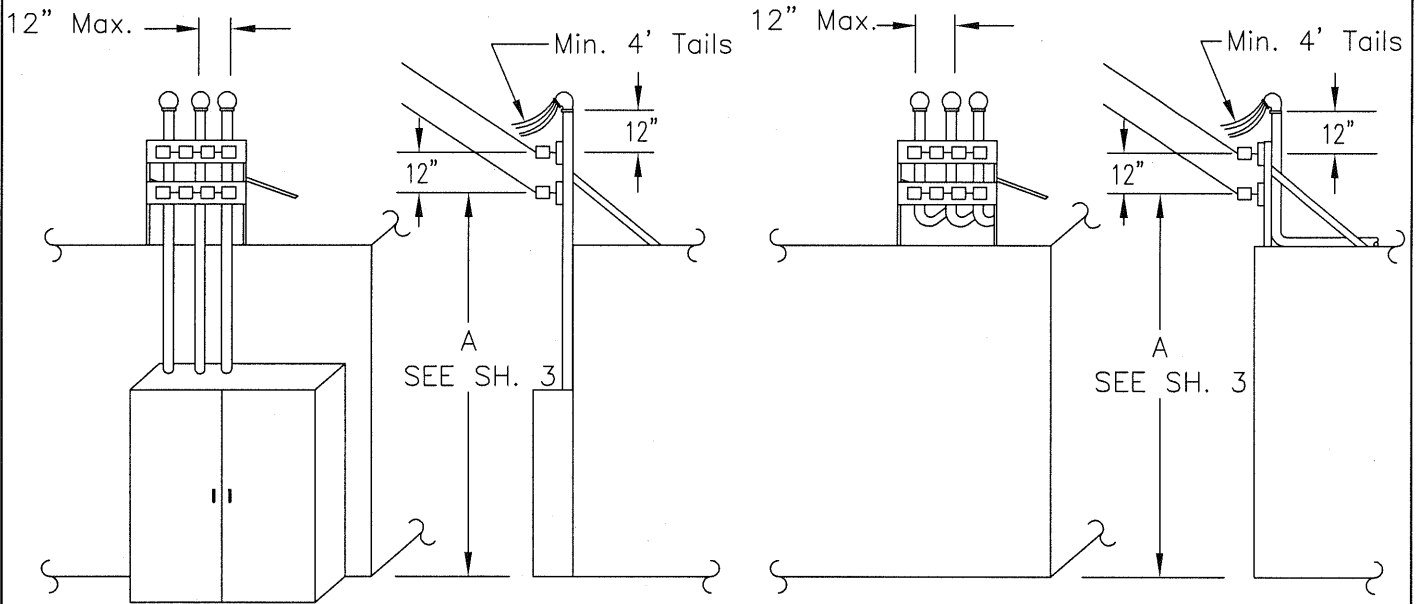

COMMERCIAL AND INDUSTRIAL
SERVICE MAST(S) ABOVE TOP OF BUILDING

NOTES:

1. Maximum number of weatherheads: 3
2. Center rack(s) below weatherheads.
3. Maximum spacing between weatherheads: 12"

5	8/18/95	Modified revision no.	P.G.	6	1/11/06	Updated information	
3	3/18/92	Added meter heights, dwg on CAD	MJK	4	7/27/93	Added Note 7	
REV	DATE		APPRVD	REV	DATE		APPRVD

DESIGNED BY: P. GRECO	ELECTRIC SERVICE REQUIREMENTS OVERHEAD	DRAWN BY: WPS
APPROVED BY: P.H.E. DATE: 3/86		SCALE: NTS DATE: 7/93
	SILICON VALLEY POWER	SHT 4 OF 4
	CITY OF SANTA CLARA	DRAWING NUMBER OH 550
		REV 6

Residential Meter Socket Configurations

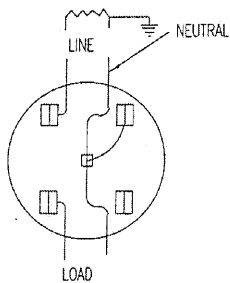

120V-1 Phase-2
FIG.1

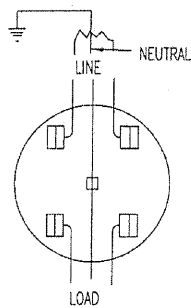

120/240V-1 Phase-3
FIG.2

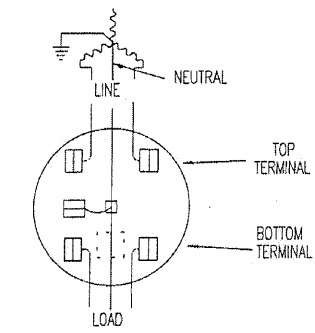

120/208V-1 Phase-3 WIRE
FIG.3

INSTALLATION GUIDELINES EXTRACTED FROM EUSERC
(Electric Utility Service Requirements Committee)

LISTING

All meter sockets, boxes and enclosures shall be listed by a qualified electrical testing laboratory acceptable to the jurisdiction having the authority.

SAFETY SOCKET BOXES

All safety socket boxes with factory installed test-bypass disconnect facilities shall be listed by a qualified testing laboratory and shall have a continuous-duty rating not less than the service equipment ampacity.

SERVICE ENTRANCE FACILITIES

The customer shall furnish, install and maintain the service entrance conductors and service equipment beyond the point of the attachment to the serving agency's overhead service drop or underground service conductors. All conductors between the overhead service outlet, underground splice box, or pull section and meter enclosure, shall be suitably enclosed and protected, and shall not be concealed except with express consent of the serving agency.

The type and size of service entrance conductors shall conform to the ordinance and codes of the local inspection authority, or where there is no ordinance requirement they shall conform to current standards of the National Electrical Code. In no case shall the service entrance conductors be smaller than #8 AWG.

In the Requirements the capacity of the service switch has been used as the basis for determining the size of other related equipment. In those cases where a main service switch is not used, the rating of the service equipment shall be considered as the service switch capacity.

In general, a building will be supplied through only one set of service conductors of the same voltage classification.

SERVICE ENTRANCE, GENERAL

All service or supply conductors shall enter the service sections through one end and leave through the opposite end of the metering transformer compartment. This stipulation applies to either overhead or underground service, or if two or more adjoining service sections are connected together.

METER LOCATIONS

- a. Electric meter installations shall be accessible to authorized representatives of the serving agency for reading, testing and inspection at all times.

Outdoor meter locations are preferred. Some of the serving agencies prohibit the installation of meters outside any building. Consult the serving agency.

- b. When adequate exterior wall space is not available, the architect or builder may provide a meter room accessible from the outside of the building, in which the required number of meter sockets may be properly installed. Consult the serving agency.

Dwellings or Apartments

Meter sockets shall be installed on or enclosed in exterior walls, and shall be located so the meters will be accessible for reading and testing without entering the building. Future building or other structural changes shall not render the meters inaccessible.

Single-Story Buildings Other Than Dwellings or Apartments

Meter sockets may be installed as required for dwellings or apartments, or installed inside the building provided they are located in a public area or meter room. Consult serving agency.

Multi-Story Buildings

Meter sockets may be installed as required for dwellings or apartments.

When the plan of a meter socket location has been established for a building, any additional meter sockets shall conform to that plan.

- c. Electric Meter Installations Shall Not Be Located In Any Of The Following Places:
 1. On any floor above the ground floor.
 2. In any hazardous location.
 3. Directly over any stairway, ramp or steps.
 4. In any doorway.
 5. In any elevator shaft or hatchway.
 6. In any projection room.
 7. In any place where moisture, fumes or dust may interfere with its operation or materially damage the meter.
 8. On any surface subject to excessive vibration, as determined by the serving agency.
 9. In any attic or place not in general use.

10. In any enclosed show window or one having a bulkhead or raised platform.
11. In any rest, bath, shower or toilet room.
12. Directly over any stove or plumbing fixture.
13. In any transformer box or on the cover of the same.
14. On any balcony or mezzanine floor, unless such balcony or mezzanine floor has a clear stairway of normal tread and rise and with utility approval.
15. On or enclosed in any bedroom wall or bedroom closet wall without permission from the serving agency.
16. On or recessed in the external surface of any wall or any building that is built within 3 feet of any property line or on the line of any walk, alley or driveway giving access to commercial or industrial property, except when permitted by the serving agency.
17. In any underground vault or other depressed location unless such location is approved by the serving agency and is accessible by a stairway of normal tread and rise. Entrance to the location shall be through a vertical doorway not less than 30 inches wide and 72 inches high.

WORKING SPACE

A level standing and working surface shall be provided and maintained in front of each metering installation. A clear and unobstructed working space shall be provided above this surface.

The width of the working space shall be sufficient to permit ready access to the metering equipment in no case less than 3 feet. The height of the working space shall be equal to the over-all height of the metering installation and in no case less than 7 feet 1 inch. The working space shall extend at least 3 feet in front of the surface on which the metering equipment is mounted and 10 inches from the meter center-line to any side obstruction and 9 inches from the meter center-line to an obstruction above the meter.

METER HEIGHTS

Meters shall be located not more than 75 inches and not less than 48 inches above the ground or standing surface when installed outdoors. When installed in a cabinet or indoors in a meter room the minimum height may be reduced to 36 inches. The master height shall be measured to the meter axis.

Exception: Utilities in some areas may require increased height.

METER SOCKETS

Sockets for self-contained meters shall be furnished, installed and wired by the customer.

Sockets for instrument transformer installations shall be furnished and installed by the customer. Refer to EUSERC Section 200 for individual utility requirements or exceptions.

METER SOCKET CONNECTIONS

For self-contained meters, the customer shall terminate his wiring. The socket shall be equipped with terminals of sufficient size to install the conductors without removing any strands of wire.

For instrument transformer-rated meters, the serving agency will furnish and install the normal secondary wiring from the metering transformers to the meter socket.

UNMETERED CONDUCTORS

Customer unmetered service wires and metered load wires are not to be run in the same conduit, raceway or wiring gutter. Metered and unmetered wires shall be separated by suitable barriers. Metered wires from the customer's distribution section (branch circuits) shall not pass through sealable sections.

GROUNDING

Lugs for terminating the user's ground wire (or other grounding conductors) shall be located outside of the sealable section, and shall be designed to readily permit the user's neutral system to be isolated, when necessary, from the serving agency's neutral.

Metering Information

Manufacturer's drawings are required in some cases prior to fabrication or installation of the services and metering equipment.

Specific instances are:

- All multiple self-contained metering equipment, 0-600 volts.
- All instrument transformer rated metering equipment, 0-600 volts.
- All standard switchboard service sections, 0-600 volts.
- Specifically engineered switchboards.
- High voltage switchboards.

Meter Socket Configurations

Self Contained	
120 volts, 2 wire - single phase	4 clip socket
120/208 volts, 3 wire - single phase	5 clip socket with the fifth clip at either 6 or 9 o'clock position
120/240 volts, 3 wire - single phase	4 clip socket
120/208 volts, 4 wire – three phase	7 clip socket
120/240 volts, 4 wire – three phase	7 clip socket
277/480 volts, 4 wire – three phase	7 clip socket
480 volts, 3 wire – three phase	5 clip socket with the fifth clip at either 6 or 9 o'clock position
Transformer Rated	
120/240 volts, 3 wire - single phase	8 clip socket
120/208 volts, 4 wire – three phase	13 clip socket
120/240 volts, 4 wire – three phase	13 clip socket
277/480 volts, 4 wire – three phase	13 clip socket; potential transformers used
480 volts, 3 wire – three phase	8 clip socket; potential transformers used

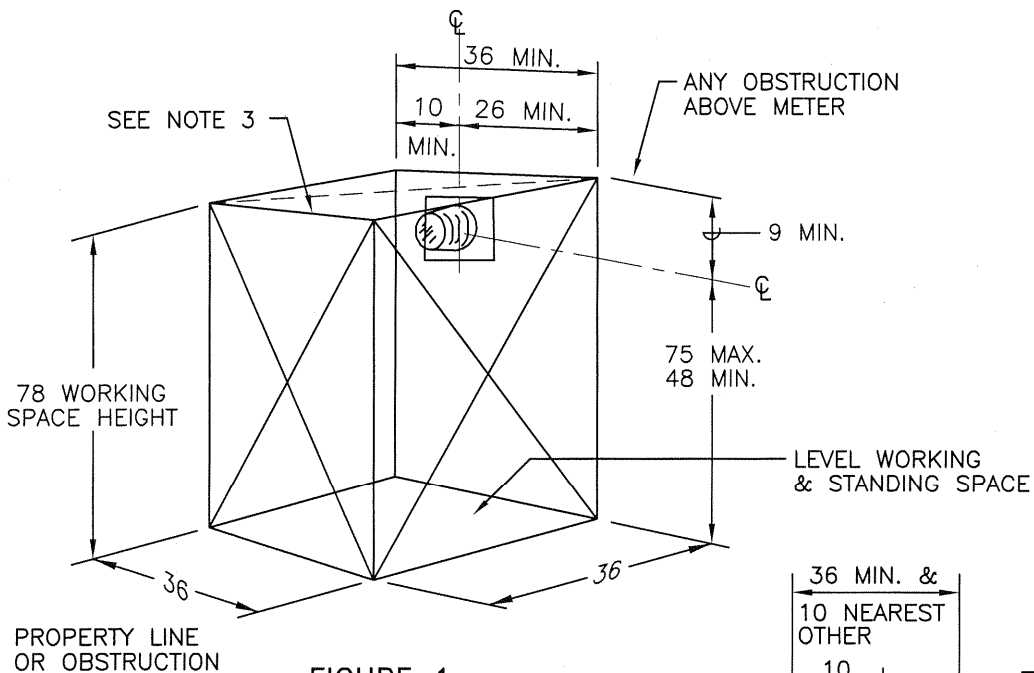

FIGURE 1
SEMI-FLUSH INSTALLATION

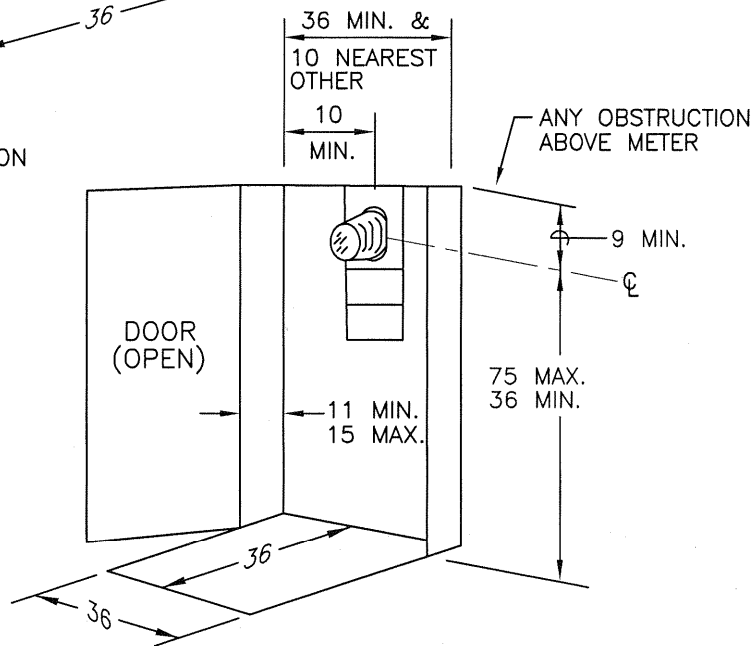

FIGURE 2
ENCLOSED INSTALLATION

NOTES:

1. Sockets with approved sealing rings shall be furnished, installed, and wired by the electrical contractor.
2. Care should be exercised to design cabinet such that neither the roof nor the door frame will interfere with the clearances or the installation of the meter.
3. Meter to be installed with 10-inch minimum clearance to the nearest side wall or other obstruction.

ALL DIMENSIONS SHOWN ARE IN INCHES

REV.	DATE	DESCRIPTION
2	05/97	REVISED DRAWING TO MEET NEC GUIDELINES - PROJECT #960205
SCALE N.T.S.		INSTALLATION GUIDE DRAWING SINGLE PHASE SELF CONTAINED METERS RESIDENTIAL SERVICE, 0-600 VOLTS
DATE 05/97		
ELECTRIC UTILITY SERVICE EQUIPMENT REQUIREMENTS COMMITTEE		SHT 1 OF 1
		DWG NO. G7 REV. 2

Trees planted more than 50 ft. from the pole or pole line

All tall trees are acceptable

- such as: Coast Redwood
- Sycamore
- Poplar
- Douglas Fir
- Valley Oak
- Palm trees

Trees planted 20-50 ft. from the pole or pole line

Plant medium trees that grow less than 40 ft.

- such as: Citrus fruit trees
- Flowering Plum
- Flowering Cherry
- Flowering Pear

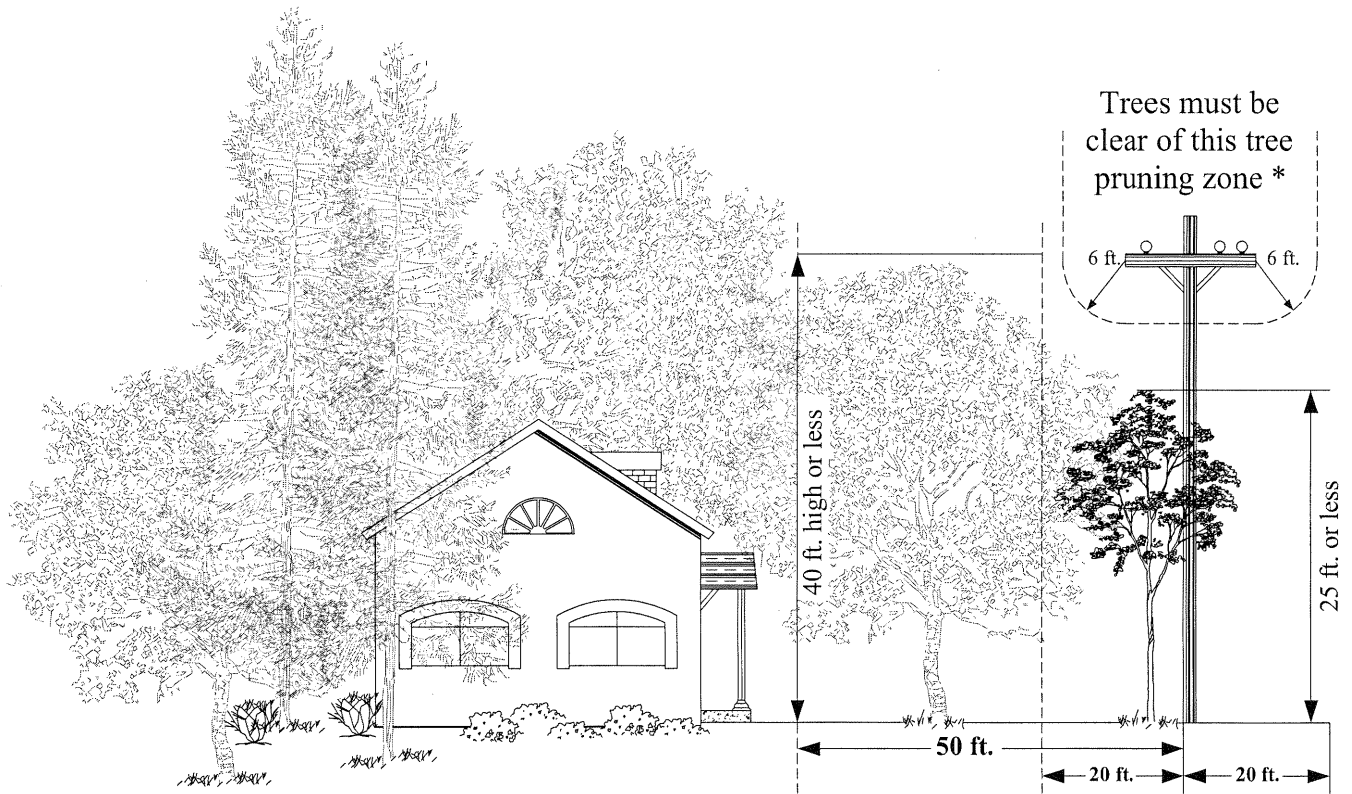

Trees planted 20 ft. or less from the pole or pole line

Plant small trees that grow less than 25 ft. high when mature

- such as: Crape Myrtle
- Japanese Maple
- Eastern or Western Redbud
- Honey Locust
- Flowering Crabapple
- Saucer Magnolia

* If you plan to plant under power lines, select a tree that will not grow into the tree pruning zone

DESIGNED BY:	EE	TREE CLEARANCES SILICON VALLEY POWER CITY OF SANTA CLARA	DRAWN BY:	EE
APPROVED BY:	LT		SCALE: NONE	DATE: 9/03
			MAP #: N/A	SHT 1 OF 1
			DRAWING NUMBER	REV 0

CITY OF SANTA CLARA
RECOMMENDED TREE LIST

Common Name	Height	Width	Flowers	Comments	Growth - Moderate(M) OR Slow(S)	Evergreen (E) / Deciduous (D)
REDBUD (eastern or western)	18'	15'	magenta	Flowers in winter; Tolerate of soils	S	D
CHINESE FRINGE TREE	20'	25'	white	Flowers Summer; Fall foliage yellow	M	D
CRAPE MYRTLE	20'	20'	pink/white/lav	Showy foliage/flowers; Tolerate soils	M	D
JAPANESE MAPLE	20'	20'	n/a	Good fall color	S	D
CALIFORNIA BUCKEYE	25'	30'	white/lt pink	Native; Large leaves/flowers; Early leaf drop	S	E
CHITALPA	25'	30'	pink/white/lav	Open growth; Flowers for weeks	M	D
FLOWERING CRABAPPLE	25'	15'	pink/purple	Round canopy; Showy leaves/flowers	S	D
HONEYLOCUST	25'	20'	n/a	Upright; Early leaf drop; 'Shademaster;	M	D
OLIVE (non-fruiting only)	25'	25'	n/a	Upright/open; Deep green leave	M	E
SAUCER MAGNOLIA	25'	20'	pink/purple	Upright; Showy flowers; Trim/tree/shape	S	D
AUSTRALIAN WILLOW	30'	25'	n/a	Upright; Leaves peculate	M	E
BRAZILIAN PEPPER	30'	30'	n/a	Upright; Dark leaves; Berries	M	E
CHINESE FLAME TREE	30'	25'	small yellow	Showy capsules/Summer; Good soil	M	D
EUROPEAN WHITE BIRCH	30'	30'	n/a	Upright growth; White bark	M	D
EVERGREEN PEAR	30'	30'	white	Spreading canopy; Early flowers; Good color	M	E
FLOWERING CHERRY	30'	20'	white/pink	Upright/spreading; Vivid flowers	M	D
FLOWERING PLUM	30'	25'	pink	Upright; Vivid flower display	M	D
GOLDENRAIN TREE	30'	25'	small yellow	Open/spreading; Showy yellow flowers	S	D
LOCUST	30'	25'	pink/purple	Upright; Showy flower clusters; Sum leaves	M	D
MAYTEN	30'	30'	n/a	Pendulous; Small leaves	S	E
SARATOGA LAUREL	30'	25'	yellow	Upright; Glossy leaf; Berries; Tolerate soils	S	E
SOUR GUM/TUPELO	30'	20'	n/a	Glossy leaves; Red/Fall; Wet soil ok	S	D
ELM (many specie)	30'+	30'+	n/a	Habits vary by specie; Shade tree	M	D
CHINESE PISTACHE	35'	30'	n/a	Round canopy; Vivid Fall color; All soils	M	D
CHINESE TALLOW TREE	35'	35'	yellow	Round canopy; Vivid Fall color; All soils	M	D
CHINESES HACKBERRY	35'	35'	n/a	Grows well in bad soil	M	D
FLOWERING PEAR	35'	25'	white	Upright; Flowers early; Reddish Fall color	M	D
JACARANDA	35'	30'	purple	Spreading habit; Leaves late; Vivid flowers	M	D
MAGNOLIA	35'	35'	white	Spreading canopy; Large leaves/flowers	M	E
PODOCARPUS	35'	30'	n/a	Round canopy; Neat/clean; Small leaves	M	E
SILK TREE	35'	35'	pink	Upright/flat canopy; Many flowers; Water	M	E
CALIFORNIA PEPPER	40'	40'	yellow	Pendulous branching; Berries	M	E
GINKGO	40'	35'	n/a	Upright; Open; Golden yellowish in Fall	S	D
LINDEN	40'	30'	n/a	Very Upright; Dense foliage	M	D
RED SUNSET MAPLE	40'	30'	n/a	Vivid fall color; Uniform shape	M	D
ZELKOVA	40'	45'	n/a	Good shade tree; Bronze Fall color	M	D
CEDAR (many specie)	40'+	40'+	n/a	Habits vary by specie; Shade tree	M	E
ASH (many specie)	45'	40'	n/a	Upright/spreading habit; All soils	M	D
LIQUID AMBER	45'	40'	n/a	Upright/spreading; Vivid Fall color	M	D
OAK (many specie)	45'+	45'+	n/a	Habits vary by specie; Shade tree	S	E or D
CAMPHOR	50'	45'	n/a	Upright/open; Glossy green leaves	M	E
COAST REDWOOD	50'	40'	n/a	Upright/spreading; More coastal	M	E
SYCAMORE 'yarwood'	50'	45'	n/a	Upright/spreading habit; All soils	M	D
PINE (many specie)	50'+	45'+	n/a	Habits vary by specie; Shade tree	M	E

Electric Generators for Back-up Power Supply

Portable or permanently installed electric generators may cause injury and property damage. Portable generators **must** be isolated from the City's electric distribution system. These generators, used during power outages, could send electricity back through the City's power lines. Silicon Valley Power crews working to restore power to your home have no way of knowing if a generator is nearby, creating back-feed on power lines thought to be de-energized. If an electric back-feed occurs, it could cause serious injury - even death.

In 1986, legislation was passed to prevent electrical back-feed. The law requires that all generators that are connected to a customer's electrical system shall be connected only by means of a double-throw switch. If connected properly, this will isolate the customer's electrical system from the City power lines while the generator is being used. State law also requires that owners, renters or lessees of electric generators used for home notify the Utility Company of the location of any generator.

If you have a generator and have not already done so, please request a generator packet by contacting SVP at (408) 261-5343 and send the completed Generator Report Form to:

Silicon Valley Power
Engineering Division
1500 Warburton Ave.
Santa Clara, CA 95050

680.5 Ground-Fault Circuit Interrupters. Ground-fault circuit interrupters (GFCIs) shall be self-contained units, circuit-breaker or receptacle types, or other listed types.

680.6 Grounding. Electrical equipment shall be grounded in accordance with Parts V, VI, and VII of Article 250 and connected by wiring methods of Chapter 3, except as modified by this article. The following equipment shall be grounded:

- (1) Through-wall lighting assemblies and underwater luminaires (lighting fixtures), other than those low-voltage systems listed for the application without a grounding conductor
- (2) All electrical equipment located within 1.5 m (5 ft) of the inside wall of the specified body of water
- (3) All electrical equipment associated with the recirculating system of the specified body of water
- (4) Junction boxes
- (5) Transformer enclosures
- (6) Ground-fault circuit interrupters
- (7) Panelboards that are not part of the service equipment and that supply any electrical equipment associated with the specified body of water

680.7 Cord-and-Plug-Connected Equipment. Fixed or stationary equipment other than an underwater luminaire (lighting fixture) for a permanently installed pool shall be permitted to be connected with a flexible cord to facilitate the removal or disconnection for maintenance or repair.

(A) Length. For other than storable pools, the flexible cord shall not exceed 900 mm (3 ft) in length.

(B) Equipment Grounding. The flexible cord shall have a copper equipment grounding conductor sized in accordance with 250.122 but not smaller than 12 AWG. The cord shall

terminate in a grounding-type attachment plug.

(C) Construction. The equipment grounding conductors shall be connected to a fixed metal part of the assembly. The removable part shall be mounted on or bonded to the fixed metal part.

680.8 Overhead Conductor Clearances.

(A) Power. With respect to service drop conductors and open overhead wiring, swimming pool and similar installations shall comply with the minimum clearances given in Table 680.8 and illustrated in Figure 680.8.

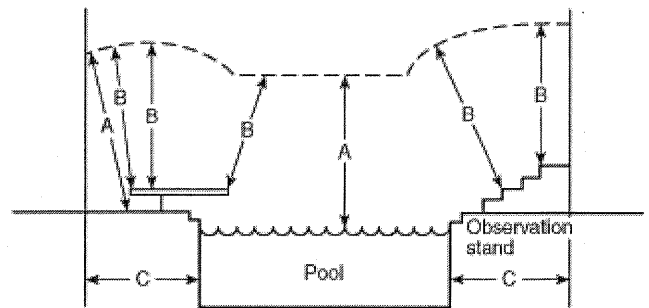

Figure 680.8 Clearances from pool structures.

FPN: Open overhead wiring as used in this article typically refers to conductor(s) not in an enclosed raceway.

(B) Communications Systems. Communication, radio, and television coaxial cables within the scope of Articles 800 through 820 shall be permitted at a height of not less than 3.0 m (10 ft) above swimming and wading pools, diving structures, and observation stands, towers, or platforms.

Table 680.8 Overhead Conductor Clearances

Clearance Parameters	Insulated Cables, 0–750 Volts to Ground, Supported on and Cabled Together with an Effectively Grounded Bare Messenger or Effectively Grounded Neutral Conductor		All Other Conductors Voltage to Ground			
	m	ft	0 through 15 kV		Over 15 through 50 kV	
			m	ft	m	ft
A. Clearance in any direction to the water level, edge of water surface, base of diving platform, or permanently anchored raft	6.9	22.5	7.5	25	8.0	27
B. Clearance in any direction to the observation stand, tower, or diving platform	4.4	14.5	5.2	17	5.5	18
C. Horizontal limit of clearance measured from inside wall of the pool	This limit shall extend to the outer edge of the structures listed in A and B of this table but not less than 3 m (10 ft).					