



8' x 14' Primary Manhole Full Traffic Installations

ISSUING DIVISION: Electric Engineering

Signed by Orville Plum's signature on file

SVP SPONSOR: Orville Plum, Electric Engineering Manager

Date Signed 3 March, 2010

PAGE: 1 OF 7

SECTION: Substructures

UG 0350

Scope of Document.....	2
Purpose of the Document.....	2
References.....	2
Rescissions.....	2
Definition of Terms	3
Work Requirements	3
Materials	3
Workmanship.....	4
Inspections	4
Permits	5
Acceptance.....	5
8' x 14' Primary Manhole – Drawing.....	6
8' x 14' Primary Manhole – orthographic view	7

Scope of Document

This document is intended for use by Contractors under contract to the City of Santa Clara and by City forces. Its purpose is to:

1. Provide a uniform electric substructure construction document for 8' x 14' primary manhole installations within the City of Santa Clara.
2. Define material requirements for 8' x 14' primary manholes.
3. Define Contractor's substructure work requirements for related manhole installations.
4. Provide a guide, with respect to utility substructures, for new electric power system projects and for changes to existing facilities.
5. Act as a supplement to detailed design drawings prepared by **Silicon Valley Power (SVP)**.

Purpose of the Document

This document outlines and details the installation of 8' x 14' primary manholes rated for installation in full traffic areas. This is a new document in the 0300 Substructures section of the Underground Construction Manual. A draft document for 8' x 14' primary manholes was prepared in 1998 as sheet 33 of UG 1000, revision 5. However, the draft document was not finalized and therefore not included in the UG 1000 revision 5 issued in 2004. The 8' x 14' manhole is intended for use in specific situations where several mainline cables may be routed through the manhole. The most likely application would be inside a distribution substation to accommodate feeder outlet cables. It differs from the standard 5' x 10' manhole in that it has duct entrances on both the ends and sides of the manhole. The additional length and width of the enclosure is to allow for cable racking and routing around duct openings.

References

ANSI F 512 - 77 "Smooth-Wall PVC conduit and Fittings for Underground Installation"
ANSI C 857-95
ASTM C 94
ASTM C 150
W.U.C. Guide 3.1 "Plastic Conduit and Fittings"
CPUC General Order 128 "Rules for Construction of Underground Electric Supply Systems"
Silicon Valley Power, City of Santa Clara, Rules and Regulations
Standard Specification 19-3.025

Rescissions

None – This is a new document.

Rev.	Date	Description	Appr.	Rev.	Date	Description	Appr.		
By: K. Keating			8'x14' Primary Manhole Full Traffic Installations				Drawn By: K. Keating		
Approved: 03 March, 2010							SHEET 2 of 7		
Kevin Keating							UG 0350		Rev.
Orville Plum									0

Definition of Terms

- **Contractor:** The person or persons, firm, partnership, corporation or combination thereof, who has entered into a contract with the City of Santa Clara, as a party or parties of the second part of his or their legal representative.
- **City:** City of Santa Clara or the City Council of the City of Santa Clara.
- **City Engineer:** City Engineer of the City of Santa Clara.
- **High Voltage (Marking):** Safety identifier of any electric system where the nominal system voltage is greater than 1000 volts. This is not the same as the NEC definition for "High Voltage".
- **Low Voltage:** Any electric system where the nominal system voltage is less than 600 volts
- **Primary:** SVP Electric facilities operating at 12,000V
- **Public Works Inspector:** City of Santa Clara Public Works Dept. Inspector, responsible for verifying proper installation and repair of all facilities within City right of ways and easements.
- **Silicon Valley Power (SVP):** Municipal Electric Department of the City of Santa Clara.
- **SVP Inspector:** Silicon Valley Power Electric Inspector responsible for verifying proper installation of electric substructures installed for use of SVP.

Work Requirements

- A. The Contractor or SVP shall furnish and install all facilities as shown and specified in the Project Specifications and/or on the detailed drawing(s). In the event of a conflict between the Project Specifications or the detailed drawings, the more stringent will apply.

Materials

A. BOXES

Precast concrete enclosures shall meet specifications noted on appropriate sheets of this drawing.

B. CONCRETE

Ready-mix Type II Concrete, 5 sack Portland Cement, 3/4" aggregate in conformance with latest ASTM Specification C-94 and C-150, unless otherwise noted in this Specification. Box concrete mixture additives shall be a maximum of 2% Calcium Nitrate and 7.5% Microsilica by weight of cement.

C. SAND

Rev.	Date	Description	Appr.	Rev.	Date	Description	Appr.		
By: K. Keating			<h1>8'x14' Primary Manhole Full Traffic Installations</h1>				Drawn By: K. Keating		
Approved: 03 March, 2010							SHEET 3 of 7		
Kevin Keating							UG 0350		Rev.
Orville Plum									0

Sand shall be clean, natural and free from clay or organic materials with 100% passing a #4 sieve and 10% maximum passing a #200 sieve. Manufactured sand aggregate is not allowed.

D. ORIGINAL SPOIL

Original spoil may be used for backfill if it is free of rock and other debris. For work done in a public right of way or public easement, a Public Works Inspector must approve use of spoil.

E. GROUND ROD CLAMP (Approved List)

Blackburn - #JAB 58H; Joslyn - #J 8592H; Dossert - #GN-62; Penn Union - #CAB-2

F. EPOXYING OF COVERS

Metallic covers for all Manholes, Pullboxes and Vaults, which are located in sidewalks, shall be sand epoxied as follows:

1. Sand blast entire cover to gray metal (Commercial blast SSPC-No. 6). Blasted area shall be coated same day as cleaned.
2. Apply one coat (min. 2 mil) Dimetcote 9HS (Americoat Corp.) over entire unit.
3. Top surface only to receive epoxy finish as follows:
 - a. One coat 72E Peace Gray Epoxy (Americoat Corp.)
 - b. Apply completely dry sand.
 - c. One coat 72E Peace Gray Epoxy.

Workmanship

A. CONCRETE

1. Forms shall be smooth and true to line and grade.
2. Forms shall be tight, of adequate strength and be completely removed upon completion of work.
3. Where material is to be embedded in concrete it shall be held securely in place.
4. Forms shall be clean and wetted prior to pouring of concrete.
5. Pouring shall be continuous, except for trench cap.

B. BACKFILL

Minimum backfill compaction shall be 90% or as required by appropriate permits or inspectors. Compaction may be accomplished by jetting with pressurized water. Compaction shall not damage or displace the work.

Inspections

A. WORK IN A PUBLIC RIGHT OF WAY OR PUBLIC EASEMENT

The Public Works Inspector shall be responsible for inspection. The Public Works Inspector will inspect all backfill. The Silicon Valley Power Inspector will be responsible only for inspecting ducts, manholes, vaults, boxes, and streetlight foundations.

Phone: 408-615-3000 for Public Works Inspector (Have permit number available).
408-640-6302 for S.V.P. Inspector (Give Estimate Number of job when calling).

Rev.	Date	Description	Appr.	Rev.	Date	Description	Appr.		
By: K. Keating			8'x14' Primary Manhole Full Traffic Installations				Drawn By: K. Keating		
Approved: 03 March, 2010							SHEET 4 of 7		
Kevin Keating							UG 0350		Rev.
Orville Plum									0

B. WORK OUTSIDE PUBLIC RIGHT OF WAY OR PUBLIC EASEMENT

The Silicon Valley Power Inspector shall be responsible for inspection and will inspect all work including backfill.

Phone: 408-640-6302 (Give Estimate Number of job when calling)

C. INSPECTOR SHALL BE INFORMED

The Inspector shall be informed at least **24 hours in advance** before commencing any installation of material in order to permit proper inspection of workmanship and materials. No work shall be embedded, backfilled or otherwise covered until such time as it has been inspected and approved by the Inspector. Any material and / or workmanship failing to meet the requirements of this Specification, good acceptable engineering or construction practices, or installed without prior notice to Inspector shall be subject to rejection. If required by the Inspector, the Contractor shall, at his own expense, remove rejected work, finish and install approved material and /or workmanship.

D. SAFETY REGULATIONS

It is the Developer's and Contractor's responsibility to comply with all applicable Safety Regulations.

Permits

For all work performed within a public right of way or public easement, a street opening permit shall be obtained from the City Engineer's Office. A street opening permit is not required for work outside of a public right of way or public easement.

For work within a California State Highway right of way, a CalTrans permit is required. Work within the right of way of a Santa Clara County road or expressway will require a County Permit. Work in the vicinity of railroad or Light Rail tracks may require a permit from the appropriate rail agency having jurisdiction over the tracks. Work in the vicinity of creeks, streams and waterways, may require a permit from the Santa Clara Valley Water District.

Acceptance

Upon completion of improvements satisfactory to SVP, SVP shall accept the work.

Rev.	Date	Description	Appr.	Rev.	Date	Description	Appr.		
By: K. Keating			8'x14' Primary Manhole Full Traffic Installations				Drawn By: K. Keating		
Approved: 03 March, 2010							SHEET 5 of 7		
Kevin Keating							UG 0350		Rev.
Orville Plum									0

8' x 14' Primary Manhole – Drawing

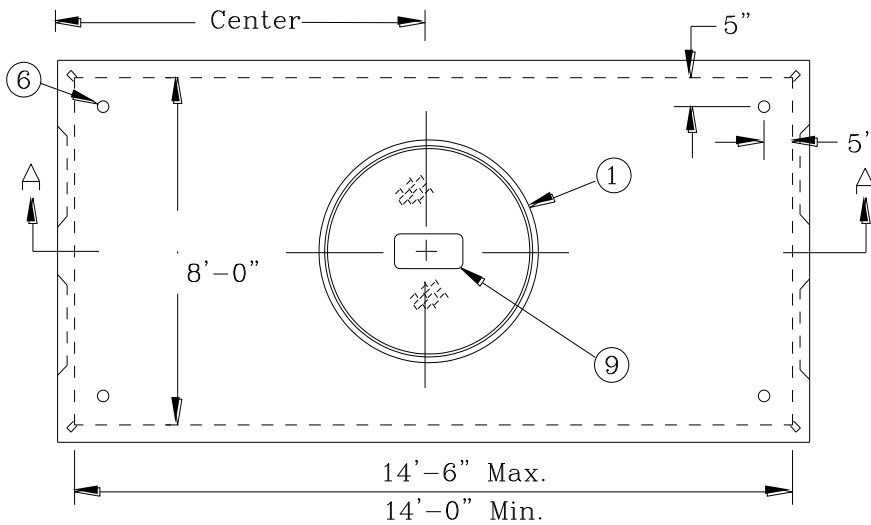

APPROVED VENDORS
UTILITY VAULT CO.

Box concrete mixture additives shall be:
2% Calcium Nitrate and
7.5% Microsilica by weight of cement.

Boxes shall meet H20-44 loading and all conditions shown on this drawing.

Excavation dimensions to be furnished by vendor.

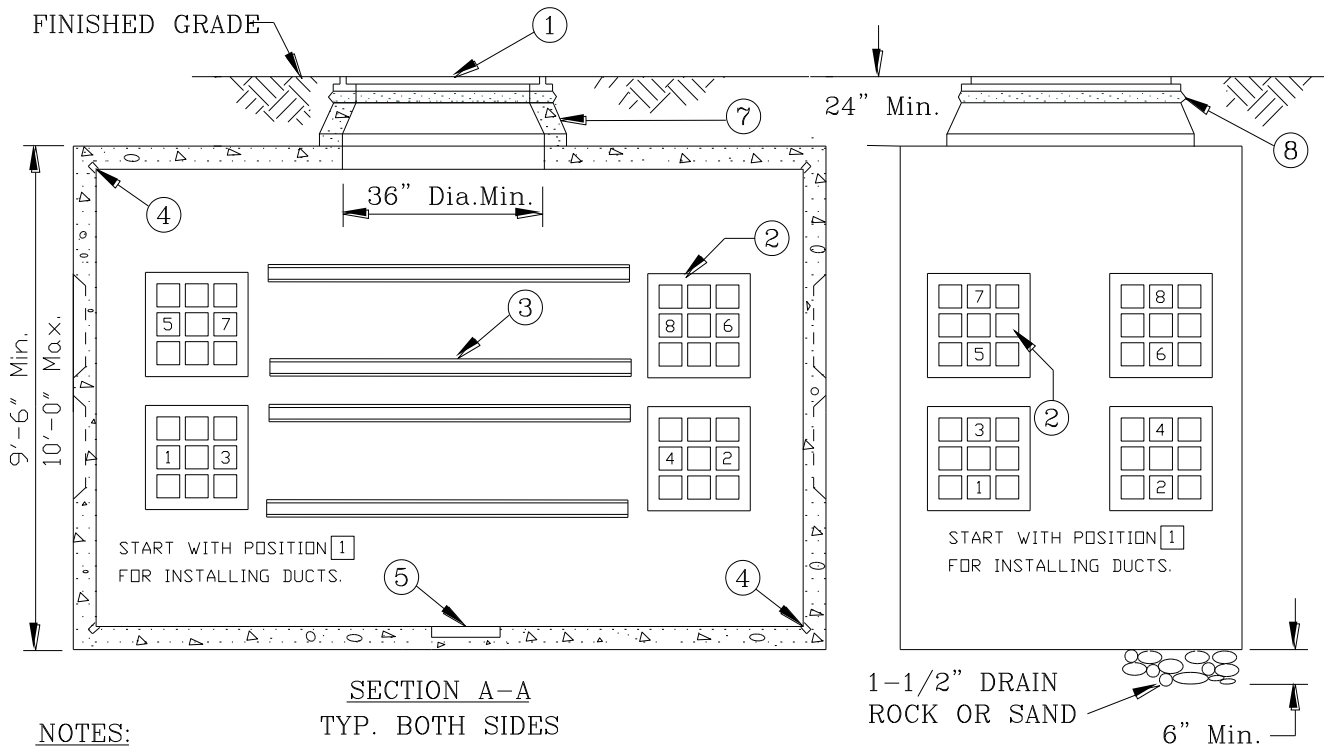

SECTION A-A
TYP. BOTH SIDES

NOTES:

- ① Steel frame and cover per UG 1000 sheets 28 & 29 (inscribed "SVP HIGH VOLTAGE").
- ② 18"x 18" knockouts section for duct entry. See UG 350 sheet 7 for dimensional details.
- ③ P-4000 Unistrut or equal cast into each vault wall. See UG 350 Sheet 7 for details.
- ④ 1"-8 UNC pulling inserts cast into vault at each corner. Typical 8 places.
- ⑤ Sump, 18" Dia. x 2 1/2" Deep. 1 required.
- ⑥ 2" Diameter knockout, typical 4 places.
- ⑦ Concrete riser(s) as required. (Note: 24" min.)
- ⑧ Grout. 3 parts sand to 1 part cement.
- ⑨ Number cover as noted on UG 1000 sheet 29 and on SVP project drawings.

Rev.	Date	Description	Appr.	Rev.	Date	Description	Appr.

By: K. Keating
Approved: 03 March, 2010
Kevin Keating
Orville Plum

8'x14' Primary Manhole Full Traffic Installations

Drawn By: K. Keating
SHEET 6 of 7
UG 0350
Rev. 0

8' x 14' Primary Manhole – orthographic view

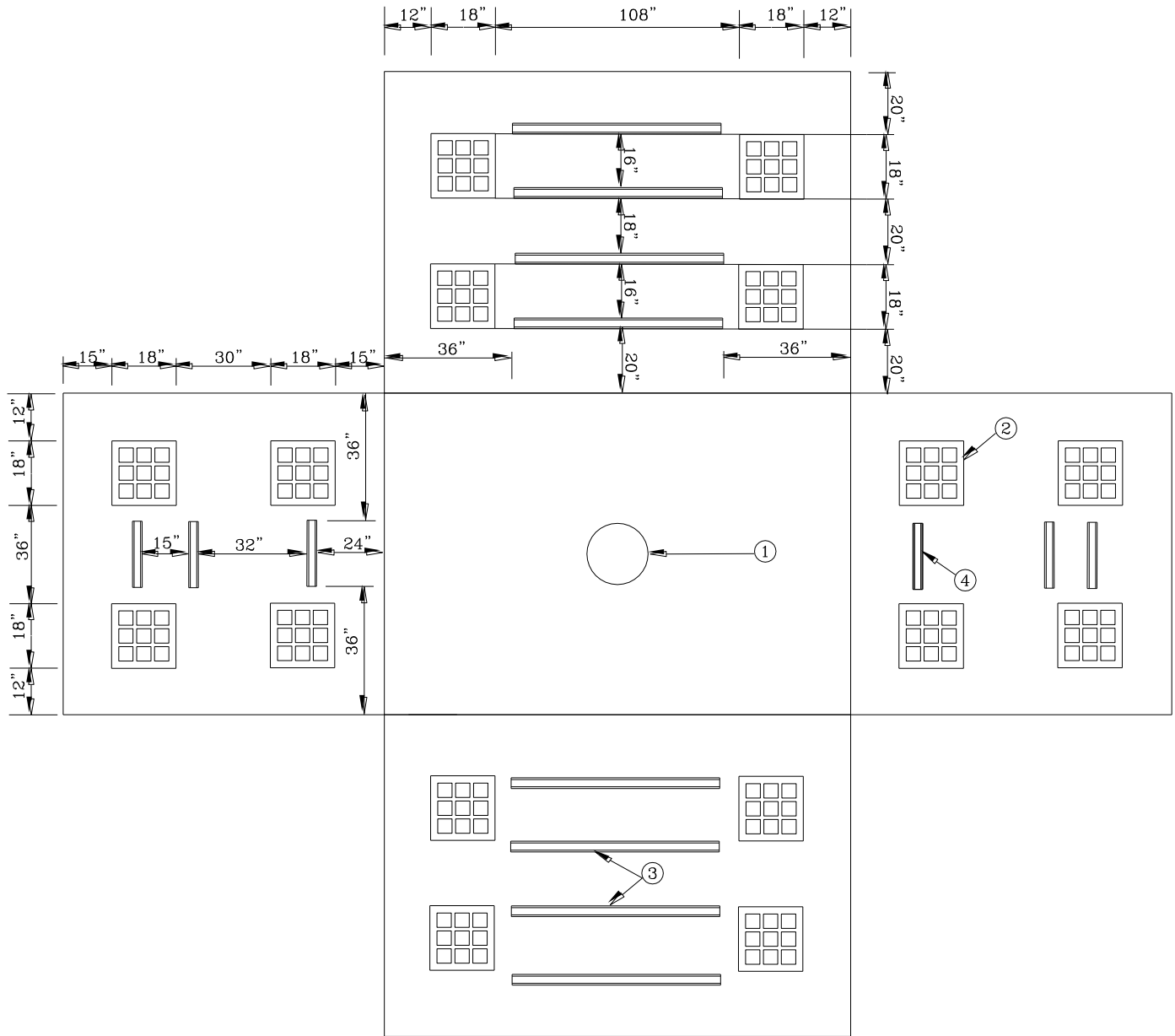

NOTES:

- ① Sump, 18" Dia. x 2 1/2" Deep. 1 required.
- ② 1-18"x 18" knockout located as dimensioned. Typical 4 per vault wall.
- ③ 8' length P-4000 Unistrut or equal cast into each vault wall. Typical 8 places.
- ④ 2' length P-4000 Unistrut or equal cast into each vault wall. Typical 6 places.

Rev.	Date	Description	Appr.	Rev.	Date	Description	Appr.		
By: K. Keating			<h2>8'x14' Primary Manhole Full Traffic Installations</h2>				Drawn By: K. Keating		
Approved: 03 March, 2010							SHEET 7 of 7		
Kevin Keating							UG 0350		Rev.
Orville Plum									0